

LCU-1232
LCU-1221

Dinel[®]

**POWER SUPPLY
AND SWITCHING UNITS**

**Automatic level control between
minimum and maximum.**



CE



- **LCU-1232**
 - **two-state control + ALARM function**
 - **for connection of three sensors (2 working - MIN, MAX, 1 emergency)**
- **LCU-1221**
 - **two-state control for connection of two working sensors (MIN, MAX)**
- **Automatic level control between minimum and maximum**
- **Pumping or draining function**
- **Connection of two-state sensors with all kinds of outputs**
- **12 V output supply voltage**

Technical specifications

Supply voltage	230 V / 50 Hz	
Power demand	4 VA	
Output voltage (terminals 5,6 - 1,2)	12 V DC	
Allowed supply voltage tolerance	± 5 %	
ALARM function	LCU-1232 LCU-1221	yes no
Maximum total load current	150 mA	
Short-circuit output current	type 500 mA	
Maximum short-circuit duration at output	unlimited	
Short circuit current of inputs	max. 6 mA	
Input terminals	after switching after disconnection tipping level	min. 2 mA max. 1 mA type 1,5 mA
Contact load capacity	max. current max. voltage max. power	3 A 250 V 500 VA
Max. switching frequency of loaded contacts	360 / h	
Contact lifetime	min. 10 ⁶ cycles	
Electric strength - mains 230V - output 12 V	4 kV	
Ambient working temperature	-20 °C ... + 50 °C	
Cover protection box	IP 20	
Cover protection terminals	IP 20	
Housing material	polycarbonate	
Terminal material	CuBe	
Max. / recommended conductor cross-section	4 mm ² / 0,5 ÷ 1 mm ²	
Weight	approx. 0,15 kg	

**Connection to 230 V mains only through a switch or circuit breaker*

**Internal protection on 230 V side by fuse T 500 mA*

**Electrical equipment of protection class II*

**Electrical safety requirements due to EN 61010-1*

**EMC EN 61000-4-2,-3,-4,-5,6,-11, EN 55011, EN 61326-1*

BASIC FEATURES

The unit has two inputs for connecting two working sensors (marked as MIN, MAX) and one input for connecting an emergency sensor (marked as ALARM - only LCU-1232). The working sensors provide control of the working relay (terminals 14, 15, 16). The emergency encoder controls the emergency relay (terminals 11, 12).

The sensor type is selected by switching the upper switch on the unit to position P (PO, PC sensors) or to position N (other sensor types). The mutual combination of PO, PC sensors with other types is not allowed. Combination of NO, NC sensors with SO, SC, RO, RC is possible.

Sensor connection options - output types

- 3-wire connection - output - open-collector PNP transistor (PO, PC)
- 3-wire connection - output - open-collector transistor type NPN (NO, NC)
- 2-wire connection - current switch - „S“ (SO, SC)
- 2-wire connection - output NAMUR (RO, RC) - only in BNV compartments
- 2-wire connection - any voltage-free contact

For minimum level (even emergency level) always choose a sensor that is open without the presence of level (PO, NO, SO, RO, etc.). For the maximum level (and emergency level), always select a sensor that is open without the presence of the level (PC, NC, SC, RC, etc.).

DIMENSIONS

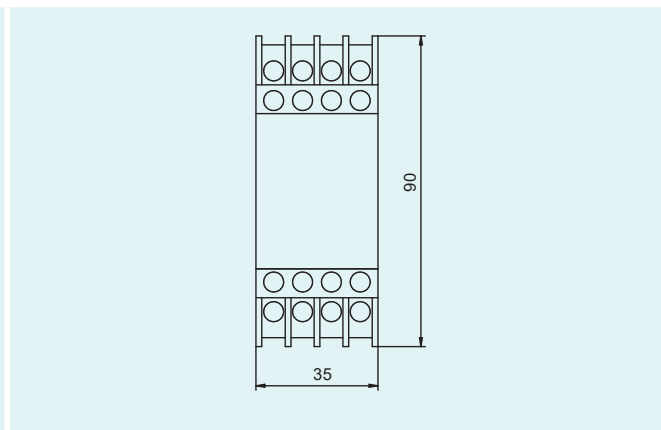
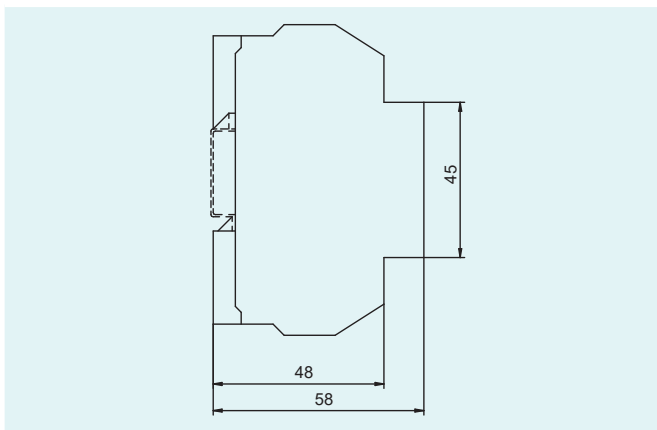

FRONT PANELS AND TERMINAL NUMBERING

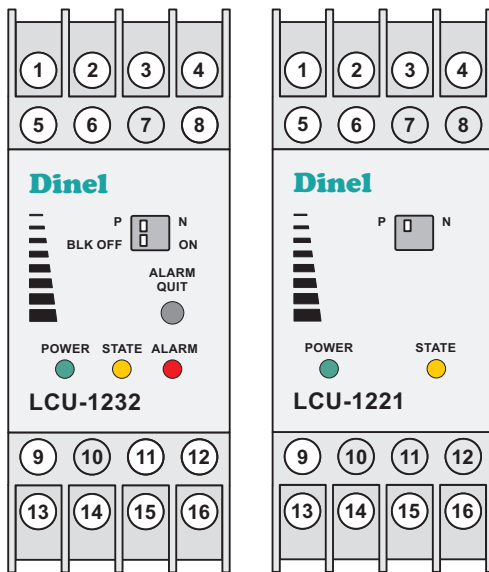

Signalling LEDs

Green „POWER“

- ON - connection of 230 VAC supply, correct function
- OFF - failure (short-circuit at supply terminals)

Orange „STATE“

- ON - contacts 15, 16 of the working relay are connected
- OFF - contacts 15, 14 of the working relay are connected

Red „ALARM“

- ON - emergency level condition - disconnected contacts 11, 12 of the emergency relay
- OFF - normal condition - contacts 11, 12 connected

ELECTRICAL CONNECTION

BLOCK AND WIRING DIAGRAM LCU-1232

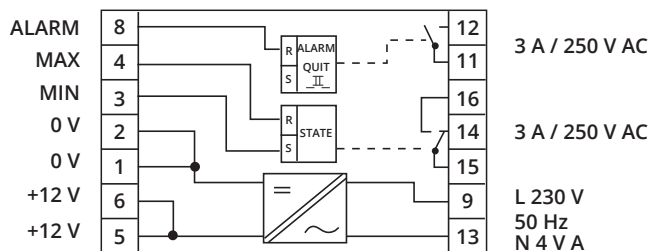

BLOCK AND WIRING DIAGRAM LCU-1221

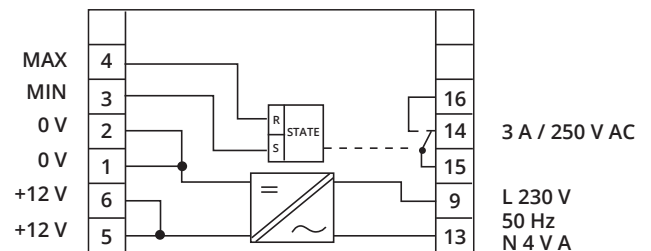

Sensor type selection

switch „P / N“

- position P
 - the unit responds to the current flowing into the input terminals (No. 3, 4, 8)
 - for PNP type sensors
- position N
 - the unit responds to the current flowing from the input terminals (No. 3, 4, 8) to the outside
 - for NPN, „S“, Namur, or voltage-free contact output sensors

switch „BLK OFF / ON“

- position OFF
 - the status of the emergency relay does not affect the status of the operating relay
- position ON
 - emergency state of the emergency relay blocks the function of the working relay and puts it into a relaxed state - contacts 15, 16 are disconnected

switch „ALARM QUIT“

- if the level is outside the emergency condition, sets the emergency relay back to the on position - contacts 11, 12 are connected



If the device is used in a way that is not specified by the manufacturer, the protection provided by the device may be violated.

FEATURES

TOPPING UP THE LEVEL

If the level drops below the sensor connected to the MIN input, the operating relay is activated (contact 15, 16 is switched on) and the yellow signalling LED (marked STATE) lights up. This starts the technological device (pump, etc.) and the level starts to rise. When the level reaches the height of the sensor connected to the MAX input, the operating relay is released (contact 15, 16 disconnected and contact 14, 15 switched on) and the STATE signalling LED is switched off.

DRAINING THE LEVEL

If the level of the medium reaches the height of the sensor connected to the MAX input, the operating relay is released (contact 14, 15 is switched on) and the STATE signalling LED is switched off. This triggers the actuator (pump, valve, etc.) and the level starts to drop. If the level drops below the sensor connected to the MIN input, the operating relay is activated (contact 14, 15 disconnects and contact 15, 16 switches on). The yellow signal LED (marked STATE) will also light up.

ALARM FUNCTION (LCU-1232 ONLY)

The ALARM input (terminal 8) can be connected to a sensor used to detect an emergency maximum or minimum. If the emergency level reaches the emergency level, the red signal LED (ALARM) lights up and the emergency relay contacts (terminals 11, 12) are disconnected. The emergency signaling lasts until the fault is corrected and the ALARM QUIT button is pressed. This then causes the ALARM LED to turn off and the emergency relay contacts (terminals 11, 12) to close.

If we require pumping or draining to be interrupted during an emergency, this can be done in two ways:

- connect the contacts of the emergency relay (they are open in case of an accident) in series with the contacts of the working relay
- switch the switch marked BLK on the unit to the ON position (see paragraph „Controls“)

MARKING OF LABELS

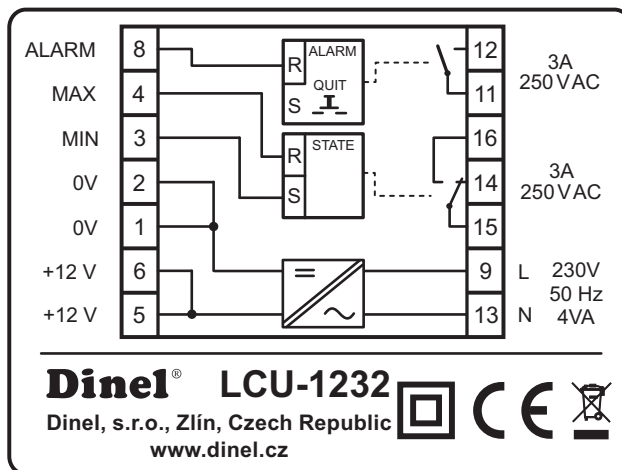
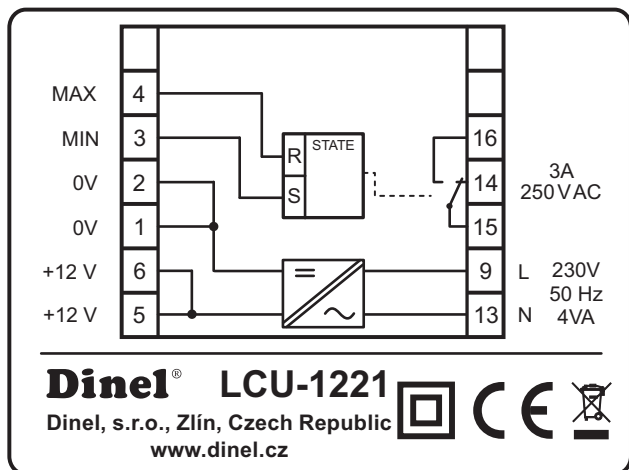

Symbol of producer: logo Dinel®

Internet address: www.dinel.cz

Country of origin: Made in Czech Republic

Double insulation sign (equipment protection class II.):

Compliance mark:

Electro-waste take-back system mark:

Block and wiring diagram.

WIRING LCU-1221

- Regulation by pumping. Connection with sensors with NPN or PNP output (e.g. DLS-27N, CPS-24N)

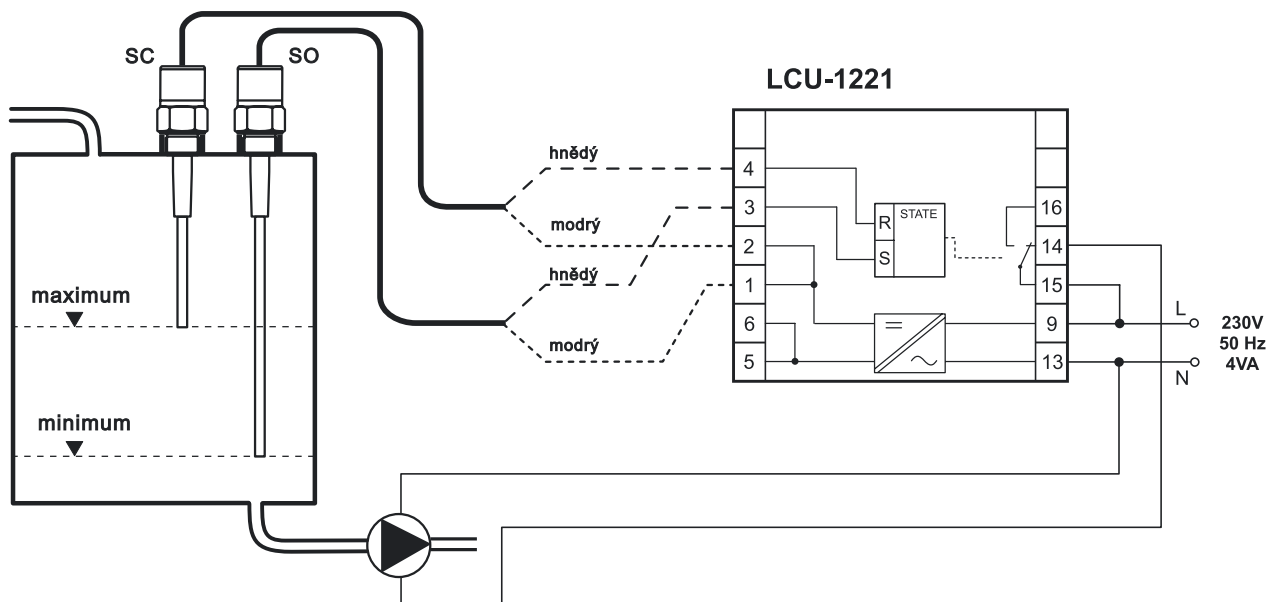

- Regulation by pumping. Connection with sensors with SO, SC output (e.g. GPLS-25N, CLS-18).

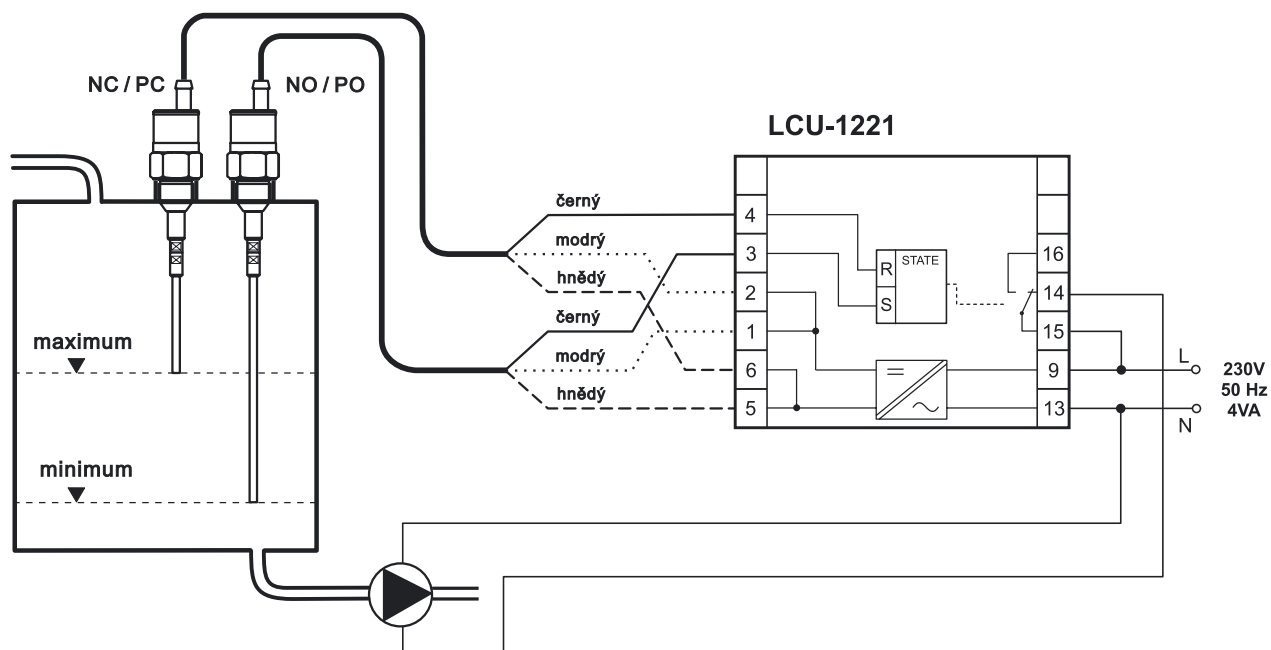

WIRING LCU-1232

- Pumping control with ALARM function detecting emergency maximum Connection with sensors with NPN or PNP output (e.g. DLS-27N, CPS-24N)

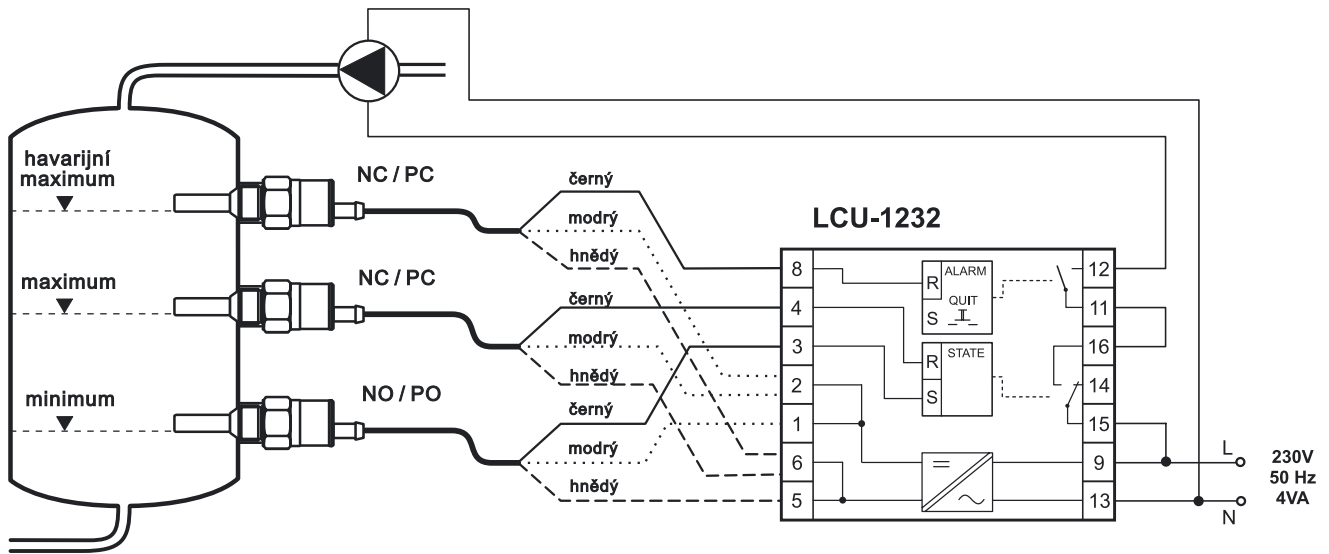

- Pumping control with ALARM function detecting emergency minimum Connection with sensors with NPN or PNP output (e.g. DLS-27N, CPS-24N)

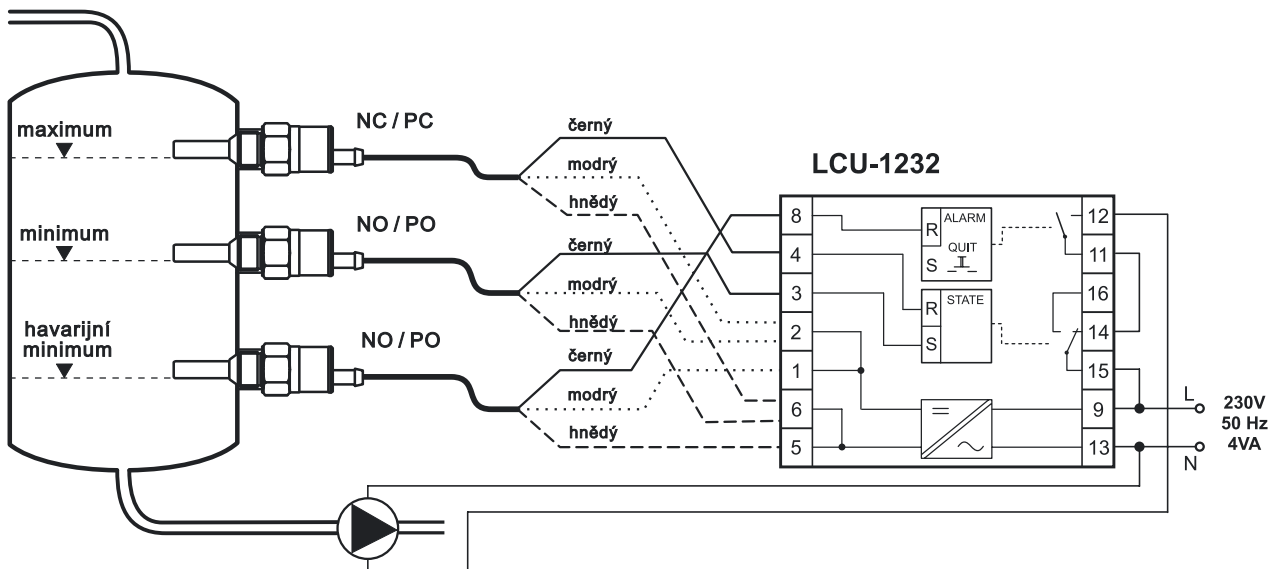

- Pumping control with ALARM function detecting emergency maximum Connection with sensors with SO, SC output (e.g. GPLS-25N, CLS-18)

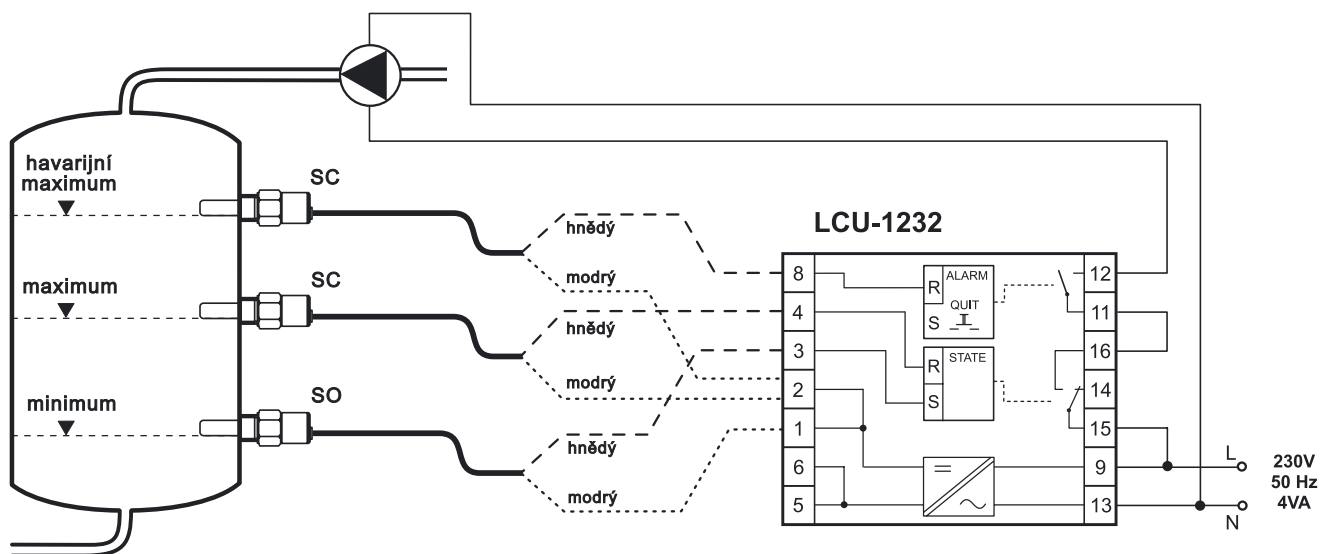

- Pumping control with ALARM function detecting emergency minimum Connection with sensors with SO, SC output (e.g. GPLS-25N, CLS-18)

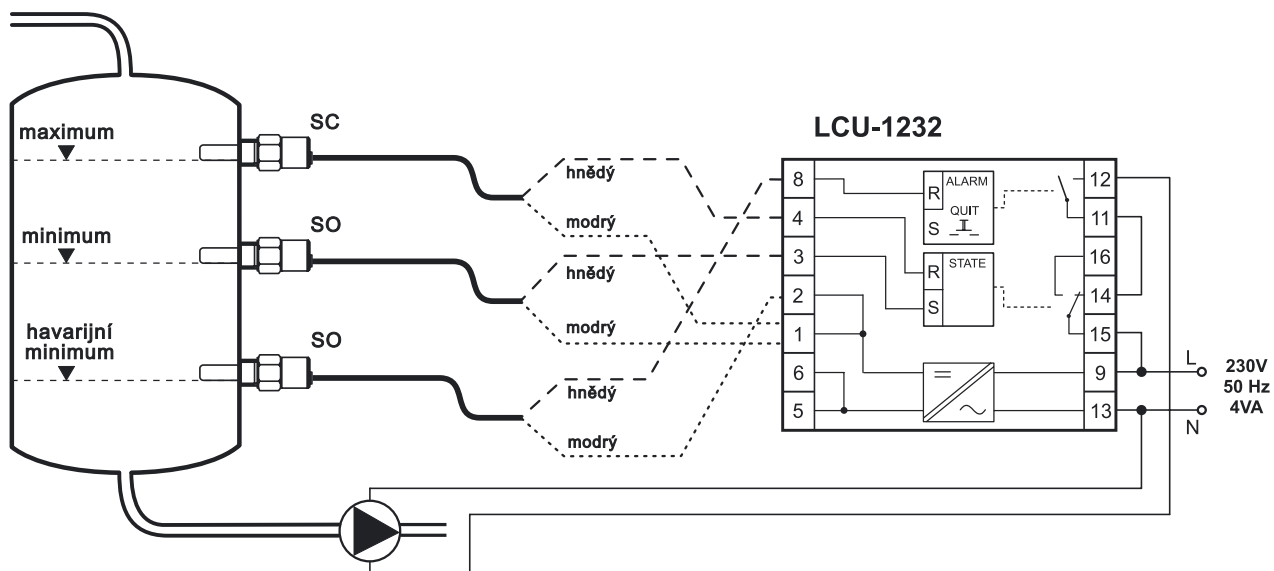

SAFETY, PROTECTION, COMPATIBILITY

The units include overload or short circuit protection at the output terminals. Electrical equipment of protection class II. Connection to 230 V mains only via a switch or circuit breaker.

Electrical safety according to EN 61010-1. Electromagnetic compatibility (EMC) is ensured by compliance with EN 61000-4-2, -3, -4, -5, -6 and -11; EN 55011 and EN 61326-1.

The device must only be connected to the power supply via an easily accessible switch with marked off/on positions and must be protected by a fuse or circuit breaker with a maximum value of 16 A!

The electrical connection must only be made in a voltage-free state!



The switch or circuit breaker used as a disconnecting means must comply with IEC60947-1 and IEC60947-3, must be marked and must not be in the mains supply.

All operations described in these operating instructions must only be carried out by a trained person or a certified person. Warranty and post-warranty repairs must be carried out only by the manufacturer.



Improper use, installation or adjustment can lead to application failures (tank overfilling or damage to system components).

The manufacturer is not liable for misuse, work loss resulting from either direct or indirect damage, or expenses incurred in the installation or use of the unit.