

VKD

Dinel[®]

TELESCOPIC BRACKET

Accessories for ultrasonic
level meters ULM and
radar level meter ARLM-70



CE

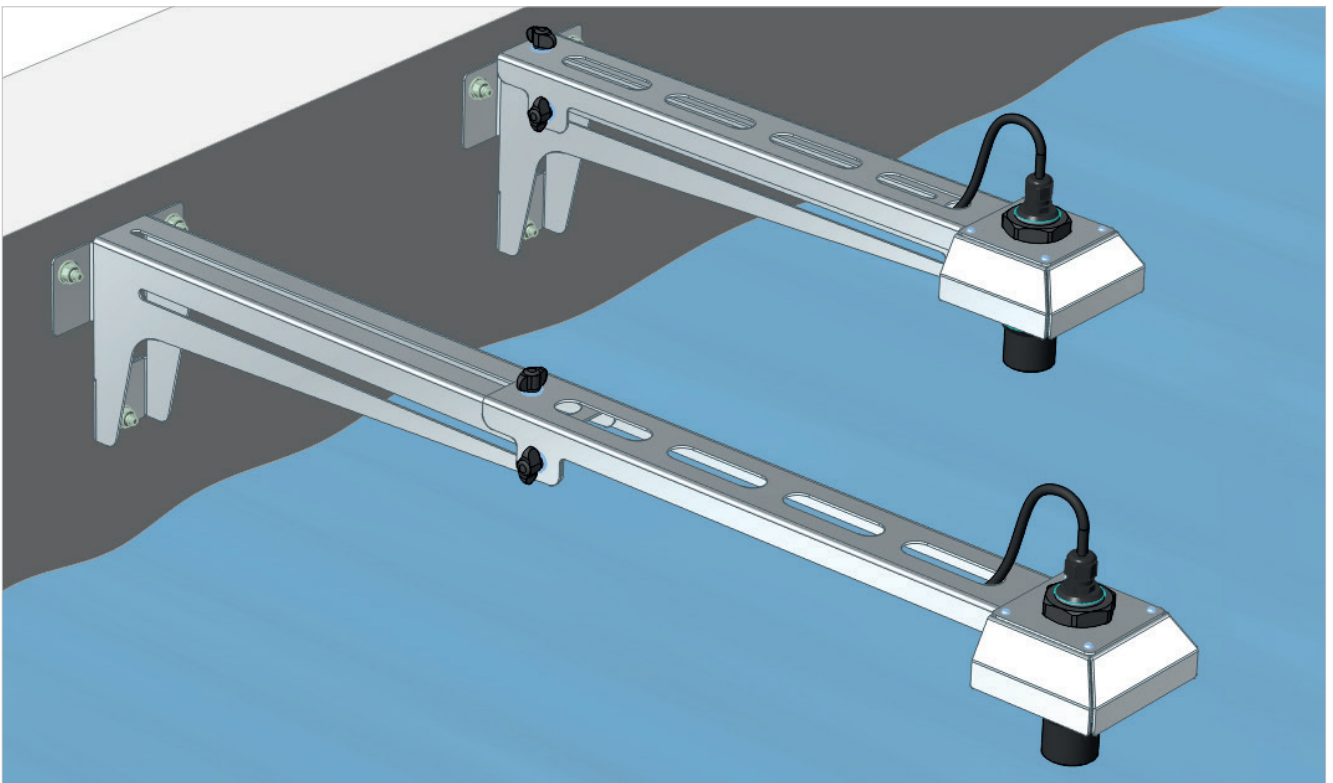

- Intended for mounting of non-contact level meters in outdoor applications - rivers, canals, dams, or for installation in tanks with open ceilings - sumps and shafts.
- Telescopic bracket allows the level meter to be mounted in the range of 50-90 cm from the wall.
- It is equipped with a protective canopy against direct sunlight, which is most effective especially when using ultrasonic level meters with upper thread (ULM-54).
- The connecting material is part of the console bracket (except for the screws for fixing to the wall - it is recommended to use 3x M8 through anchor).

Technical specifications

Device mounting range from wall	510 - 900 mm	
Process connection	G3/4"	ULM-53-01
	G1"	ULM-53-02; ULM-54-02; ULM-54-06; ULM-54-10; ULM-70-02
	G1 1/2"	ULM-53-06; (ULM-54-06); ULM-70-06
	G2"	ARLM-70
Material	G2 1/2"	ULM-53-10; (ULM-54-10); ULM-70-10
		steel W. Nr 1.4301 (AISI 304)
Weight	~ 2,1 kg	

DIMENSIONS

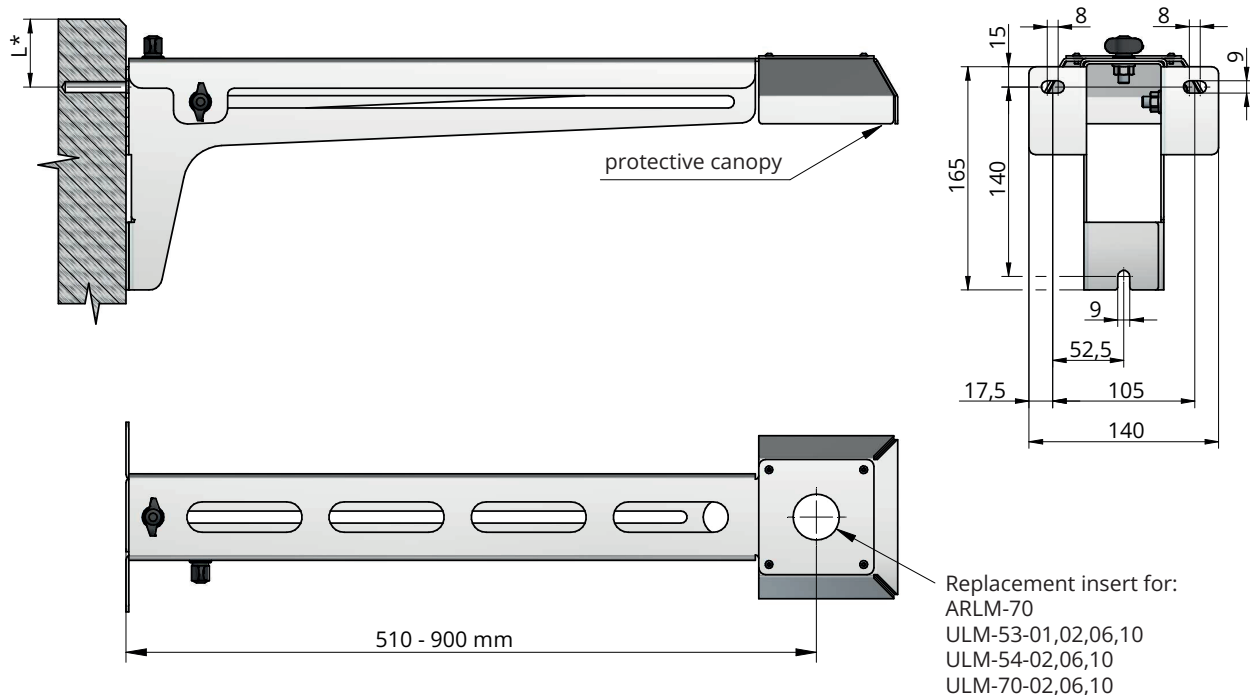

* The distance of the holes from the upper edge of the wall should be chosen with regard to the material and its quality.

ORDER CODE

VKD

PROCESS CONNECTION

G3/4	for level meter ULM-53-01
G1	for level meter ULM-53-02; ULM-54-02; ULM-54-06; ULM-54-10; ULM-70-02
G1,5	for level meter ULM-53-06; (ULM-54-06); ULM-70-06
G2	for level meter ARLM-70
G2,25	for level meter ULM-53-10; (ULM-54-10); ULM-70-10

VKD - G3/4

CODE EXAMPLE

Dinel, s. r. o.
 U Tescomy 249, 760 01 Zlín, Czech Republic
 tel.: +420 577 002 003
 e-mail: sale@dinel.cz

www.dinel.cz

version:
10/2024

