

CLM-40

Dinel®

CAPACITIVE LEVEL METER

For continuous level measurements of diesel fuel, oils and other petroleum products in trucks, building machines, locomotive engines etc.



CAN CE



- For continuous level measurement of diesel fuel in trucks, building machines, locomotives, etc.
- Direct mounting into a tank through the 5-hole flange
- Arbitrary electrode length (max. 1 m)
- Possibility of shortening electrodes to the desired length
- Current (4 ... 20 mA) or voltage (0 ... 10 V) output, or communication protocol CAN
- Setting by means of magnetic pen

TECHNICAL SPECIFICATION

Supply voltage	CLM - 40N-40-_-I CLM - 40N-40-_-U CLM - 40N-40-_-CAN	9 ... 30 V DC 12 ... 30 V DC 9 ... 30 V DC
Type of Output	CLM - 40N-40-_-I CLM - 40N-40-_-U CLM - 40N-40-_-CAN	4 ... 20 mA (Limits 3,9 ... 20,5 mA) 0 ... 10 V (Limits 0 ... 10,2 V) Protocol CAN SAE j1939 (FMS)
Current consumption	CLM - 40N-40-_-I CLM - 40N-40-_-U CLM - 40N-40-_-CAN	3,75 ... 20,5 mA max. 5 mA 10 mA (Max. 16 mA)
Load resistance	CLM - 40N-40-_-I CLM - 40N-40-_-U	$R_z \leq (U - 9) / 20,5$ [kΩ; V] $R_z \geq 5$ kΩ
Nolinearity		max. 1 %
Temperature error		max. 0,05 % / K
Voltage error		max. 0,3 μA/V
Internal resistance / Electric strength (Electrode - Housing)		1 MΩ / 200 V DC
Coupling capacity / Electric strength (Housing - Supply leads)	CLM - 40N-40-_-I CLM - 40N-40-_-U CLM - 40N-40-_-CAN	91 nF / 500 V DC 50 nF / 500 V DC 49 nF / 500 V DC
Coupling capacity / Electric strength (Electrode - Supply leads)		47 nF / 500 V DC
Protection class		IP 68
Ambient temperature range		- 40 ... +85 °C
Cable	CLM - 40N-40-_-I CLM - 40N-40-_-U CLM - 40N-40-_-CAN	PUR 2x1 mm ² PUR 3x0,75 mm ² PUR 2x2x0,25 mm ² , shielded
Process connection	CLM - 40N-40-F5-_ CLM - 40N-40-G-_	Flange with 5 holes Thread G 1"
Cable gland	CLM - 40N-40-_-V CLM - 40N-40-_-H	cable gland with spiral relief cable gland for protective hose (AD 10,0)
Weight (exclude electrode)		approx. 0,3 kg
Error indication Settings	CLM - 40N-40-_-I CLM - 40N-40-_-U (0..10 V) CLM - 40N-40-_-U (0..5 V)	3,75 mA 10,5 V 5,5 V

BASIC FEATURES AND USE

Capacitive level meter CLM® is intended for continuous measurement of the level of fuel (diesel). It consists of a measuring electrode and the electronics housing to which is firmly attached the cable. The electronic part converts the capacity to the current or voltage signal. For accurate measurements independent on the tank shape is the rod electrode placed inside the reference tube. The level meter has no setting elements, neither mechanical moving parts and so its installation is very simple. The production of its electrodes is possible in any length in the range 100 ... 1000 mm, so that the level meter can go through entire height of the tank. Mounting of the tank level meter is done by using 5-hole flange (SAE).

VARIANTS

code	electrode type	electrode length
CLM-40N-40	non-insulated bar electrode with reference tube	0,1 ... 1 m

DIMENSIONS

CLM-40N-40-F5

CLM-40N-40-G1

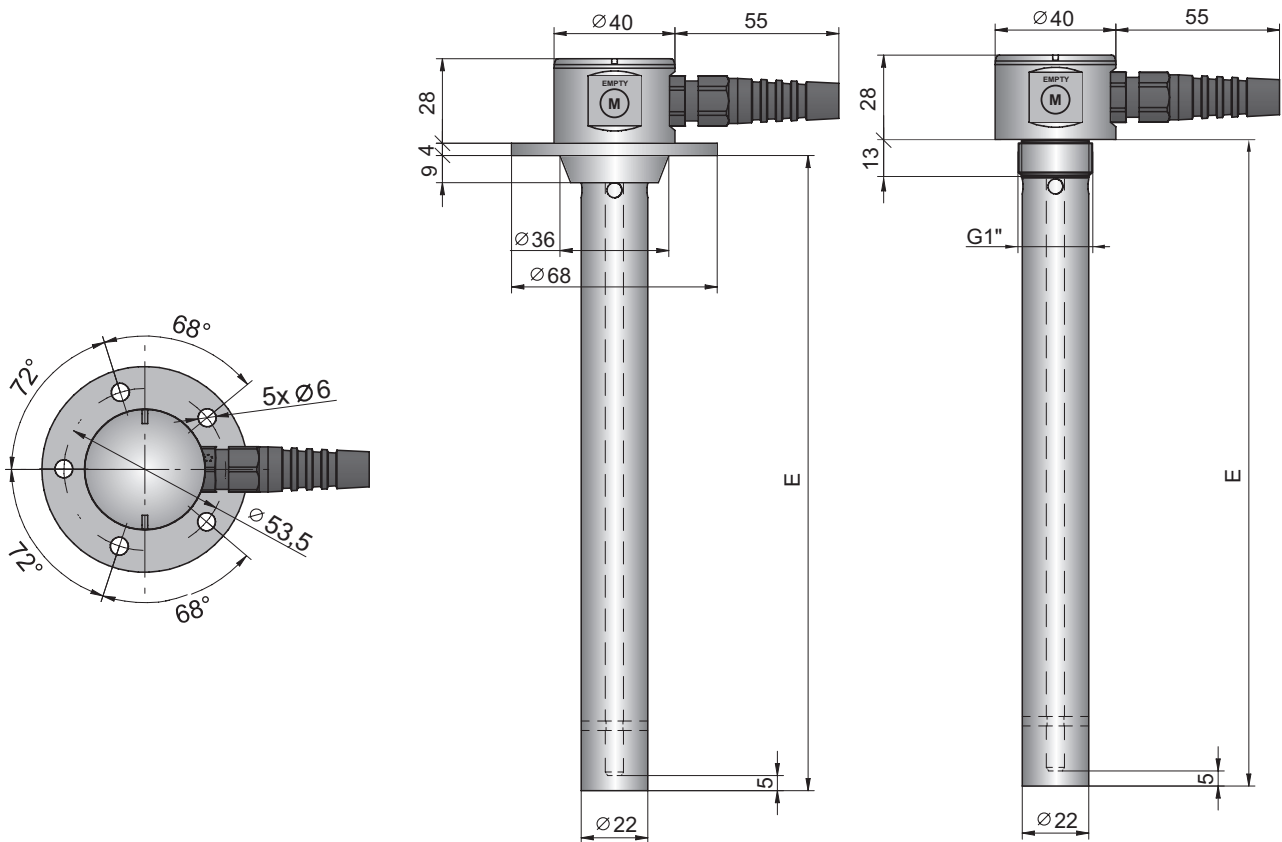

TECHNICAL SPECIFICATIONS

MATERIAL PERFORMANCE

sensor part	standard material
Housing	stainless st. W. Nr. 1.4305 (AISI 303)
Cable gland	PA
Cable	cover PUR, individual wires PVC
Electrode	stainless st. W. Nr. 1.4404 (AISI 316 L)
Reference tube	stainless st. W. Nr. 1.4301 (AISI 304)
Process flange	stainless st. W. Nr. 1.4305 (AISI 303)
Insulating bushing	PA + GF30

INSTALLATION AND OPERATION

Level meters are installed in vertical position. Mounting of the tank level meter is done by using 5-hole flange (SAE). Distance from the wall may be arbitrary and distance from the bottom is recommended min. 10 mm.

Under the flange of the level, it is necessary to put in the **rubber gasket** resistant to petroleum products (see. Accessories).

On the area of contact seals the tank flange is applied **silicone sealant** resistant to petroleum products. It is recommended to apply sealant Gasket seal from Soudal or Loctite 5922

The sensor is mounted with screws M5 5. Recommended **tightening torque** of **5.5 Nm** for the bolts of material type 8.8 (8G).

Measurement range sensor is adjusted by applying a magnetic pen on sensitive pads (see Instructions). Measuring the level of **other media** (biodiesel, oil, etc.) **must be consulted with the manufacturer** (readjustment of the level meter).

The level meter can be also used for **similar applications** in stationary tanks, containers, etc

ELECTRICAL CONNECTION

The level meter is designed to be connected to processing (display) units through PUR cable. Cable glands may be in design "V" with a spiral relief in case of increased mechanical wear on the cable or in variant "H" with cable gland for protected hoses. Wiring diagrams are shown in the following pictures.

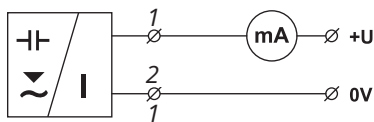

Level meter with current output connection (I)

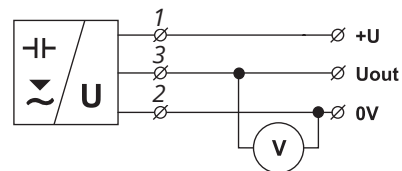

Level meter with voltage output connection (U)

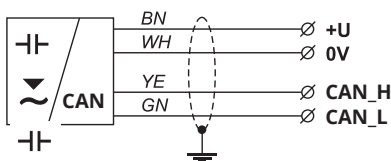

Level meter with CAN line output connection

Wiring colours:

- 1,2,3 – Nr. of cable
- BN – Brown
- BU – Blue
- WH – White
- YE – Yellow
- GN – Green
- ⏏ – Cable shield

AREAS OF APPLICATION

Capacitive level meter CLM® is intended for continuous measurement of the level of fuel (diesel) in tanks of trucks, construction and agricultural machinery, locomotives etc. After consultation with the manufacturer can be used for measuring and other non-conductive liquids (eg.: biodiesel, oil, etc.).

ORDER CODE AND CORRECT SPECIFICATION EXAMPLE

ORDER CODE

CLM-40

FINISH

N non-explosive environments

ELECTRODE TYPE

40 non-insulated bar electrode with reference tube

PROCESS CONNECTION

F5 flange with 5 holes

G1 thread G1"

OUTPUT TYPE

I current (4 ... 20 mA)

U voltage (0 ... 10 V)

CAN digital line CAN SAE j1939

CONNECTION METHOD

V plastic cable gland with spiral

H plastic cable gland for protective hose

ELECTRODE

E electrode length in mm

KABEL

K cable length in m

CLM-40 N - 40 - G1 - I - V - E 1000 K 2 **EXAMPLE OF CODING**



SETTING

Adjustment is made by placing the magnetic pen on the sensitive surfaces of the level gauge, which are marked „EMPTY“ and „FULL“.

For the variant with CAN type output, the software application „Basic SCADA fuel“, which is freely available on the website www.dinel.cz, can be used for more detailed configuration and collection of measured data.

Note: The level gauge is factory preset for diesel fuel measurement.

ACCESSORIES

magnetic pen	included in the price	MP-8	
programme Basic Scada Fuel meter (for CAN version)	free-to-download		
extra cable (over the standard length 2 m)	at extra cost		
rubber seal 5 otv NBR (for flange with 5 holes)	at extra cost		
converter UCC-011 (for CAN version)	at extra cost		
protective hose (for version with connector H)	at extra cost		

CERTIFICATION

The level gauge has been certified by the Ministry of Transport and Communications of the Czech Republic ATEST 8SD under number 3482. ATEST 8SD approves the technical suitability of a type of vehicle component or vehicle equipment.

The tests and assessment for the approval of the technical suitability of the fuel level gauge type CLM-40N designed for steel tanks were carried out by the testing laboratory TÜV SÜD Czech s.r.o., Prague. The CLM-40N product fulfils the requirements of Act No. 56/2001 Coll. with the following:

- when installing it is necessary to ensure professional installation (follow the installation instructions),
- the manufacturer indicates the approval in the document given to the customer when the product is sold,
- the manufacturer shall mark the products with the prescribed marking according to the draft mandatory marking.

SAFETY, PROTECTIONS AND COMPATIBILITY

Level meter CLM-40 is equipped with protection against electric shock on electrode, reverse polarity, output current overload, short circuit and short time over voltages.

Electromagnetic compatibility is provided by conformity with standards: EN 55022/B, EN 61326-1, EN 61000-4-2, EN 61000-4-3, EN 61000-4-4, EN 61000-4-5, EN 61000-4-6.

The manufacturer reserves the right to change the specifications and appearance of the product without prior notice.

Dinel, s. r. o.
U Tescomy 249, 760 01 Zlín
tel.: +420 577 002 000
e-mail: sale@dinel.cz

www.dinel.cz

version:
09/2024

