

PCU-100

Dinel®

PROGRAMMABLE DISPLAY UNIT

For measuring, displaying and archiving physical quantities (level, pressure, flow, temperature, etc.).



HART
COMMUNICATION PROTOCOL



BASIC TECHNICAL DATA

Supply voltage	85 ... 253 V AC
Rated power consumption	6 VA
Outlet	1x SSR relay max. 250 V AC / 100mA
Inlet	active current loop (4 - 20 mA) power supply 24 V +/- 10%, serial impedance <110 Ω
Measuring accuracy	+/- 0,1%
Display type	graphical LCD 132 x 32 px with backlight
Control	film keyboard - 4 buttons, PC program - micro USB connection
Internal memory size	min. 500 000 records
Archiving Period	user adjustable (1 sec to 8 hours)
Language	Czech, English
Dimensions	110 x 80 x 65 mm
Weight	320 g
Housing - material	ABS/PC
Protection class	IP65
Ambient working temperature	-25°C to +50°C

- Universal industrial data logger, optionally with six-digit display function (PCU-100-D).
- Single input channel - 4-20 mA current loop, optionally with HART® protocol support for digital data transfer (PCU-100-_-H).
- Connection to PC via micro USB port, clear application (download at www.dinel.cz) for setting up the unit and the connected sensor (HART® supported version only).
- Includes power supply for the sensor (transmitter).
- Easy to read backlit LCD display with configurable display, including bargraph.
- Large selection of display units, including user-defined.
- Data storage with user-defined period on internal continuously overwritten FLASH memory.
- FLASH memory capacity 500,000 records.
- Option to export data to microSD card (periodically or when internal memory is full).
- Many conversion characteristics: linear, quadratic, square root, user-defined tables with linear approximation or conversion to volume according to specified tank parameters.
- Battery-backed real-time circuit.
- Fully user-defined relay output (alarm, two-position control).
- Extendable with communication modules.
- Supply voltage 85-253 V AC.

RANGE OF APPLICATION

Programmable control unit can be used as a universal industrial data logger for monitoring of a measured value. Thanks to a relay output, it is also possible to use the unit for the control of the process of measured value using two-state control.

BASIC FEATURES AND USE

Programmable control unit PCU-100 is used for measurement, displaying and archiving of the physical value (liquid level, pressure, flow, temperature, etc.). One transducer of physical magnitude with an analogue 4-20 mA output can be connected to the unit.

Different types of conversion (converting) characteristics (linear, square, root and user defined), may be selected, also the tank dimensions for conversion to the volume of the media may be specified. The unit is also available in the version without graphic LCD display that is replaced with the status LEDs. The unit has a battery backed real-time circuit. Archiving with user-defined period takes place on the internal flash memory with a capacity sufficient for more than 500,000 samples. Data can be exported to a micro SD card for additional processing.

User configuration is possible through a regular desktop application after connecting a PC via a micro USB connector located on the front panel of the unit. For the version fitted with an LCD display the configuration is also possible using the graphical menu and four membrane keys.

The unit is equipped with one input settings in the hardware configuration according to the type of unit. One relay output is fully user-configurable, including the possibility of two-state control. The functionality of the unit is expandable with optional modules. The units are built into the ABS/PC instrument boxes intended for wall mounting. Connection terminal is located inside the device.

VERSIONS

code	display type
PCU-100-D	Front panel with a graphic LCD display and a membrane keypad. The entry depending on configuration (for connecting one sensor), one relay output.
PCU-100-L	The front panel without an LCD display with status LEDs. The entry depending on configuration (for connecting one sensor), one relay output

DIMENSIONS

PCU-100

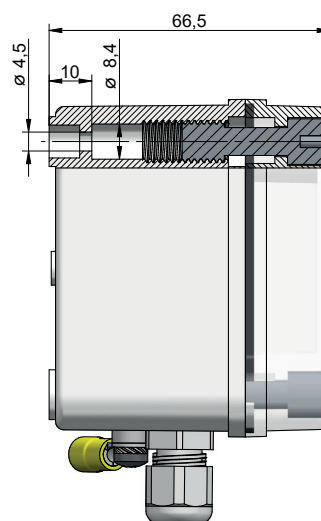
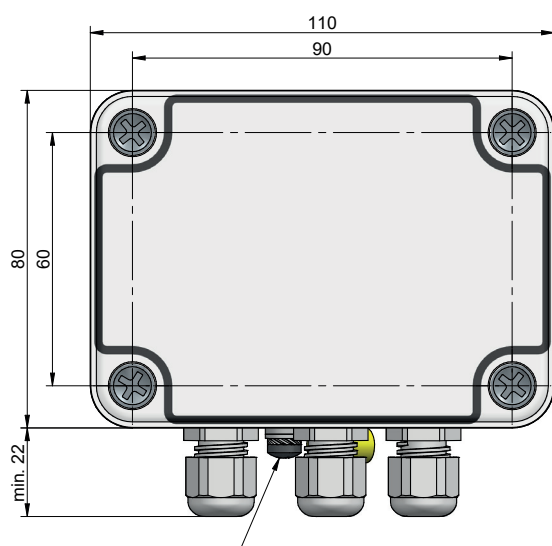

DIMENTIONAL DRAWINGS

PCU-100-D

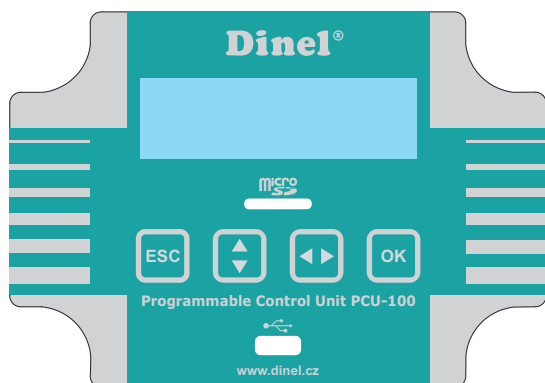

PCU-100-L

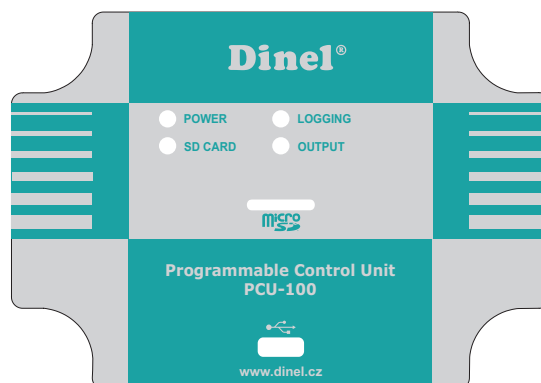

Terminal plate: PCU-100-X-I

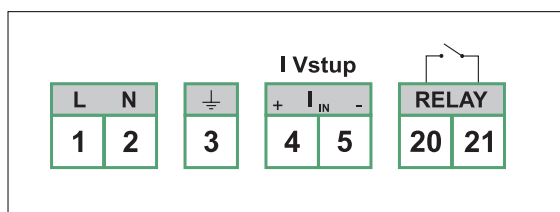

Terminal No.	
1	L (85-253 VAC)
2	N (85-253 VAC)
3	⊥ Functional grounding
4	Current input +
5	Current input -
20	RE 1 (100 mA / 250 VAC)
21	RE 1 (100 mA / 250 VAC)

TECHNICAL PARAMETERS

ELECTRICAL PARAMETERS OF THE RELAY OUTPUT

Maximum switched voltage	±50 V DC / 230 V AC
Max. switched current	±120 mA DC / 80 mA AC
Maximum resistance is in the closed state	30 Ω
The maximum current flowing through the opened contacts	1 μA (U = 100 V)
Insulating Voltage	5 kV AC (RMS)

MECHANICAL ASSEMBLY

- A number of evaluation units PCU-100-X is designed to be installed on a wall using four mounting screws or bolts (hereinafter referred to as "the screws").
- When installing the device, it is first necessary to withdraw the transparent polycarbonate housing of the front panel that is held in place by 4 plastic screws. The mounting holes designed for screws for attaching to the wall are located under the plastic screws. Using the screws, the unit is fixed in the required position on the wall. Now, it is possible to connect the cables to the terminals.
- Then, return the transparent cover to the place on the front panel and its plastic screws are sufficiently tightened to achieve full coverage.
- The prescribed tightening torque is 3 Nm.



Be extremely careful when placing the cover in place. It is not possible to settle the front cover arbitrarily, there are located protrusions on the bottom of the housing and on the body of the boxes. At bad settlement, these protrusions may prevent the full engagement of the seal and the achievement of full coverage.

ELECTRICAL CONNECTION

The electrical connection is made to the terminal block of the device. For an access to the terminal block, it is required:

1. Remove the transparent front polycarbonate housing (see chapter Mechanical assembly)
2. Grip the front panel on the sides by the grips intended for this purpose (see figure below)
3. Pull evenly on both sides to eject the front panel from the connector.

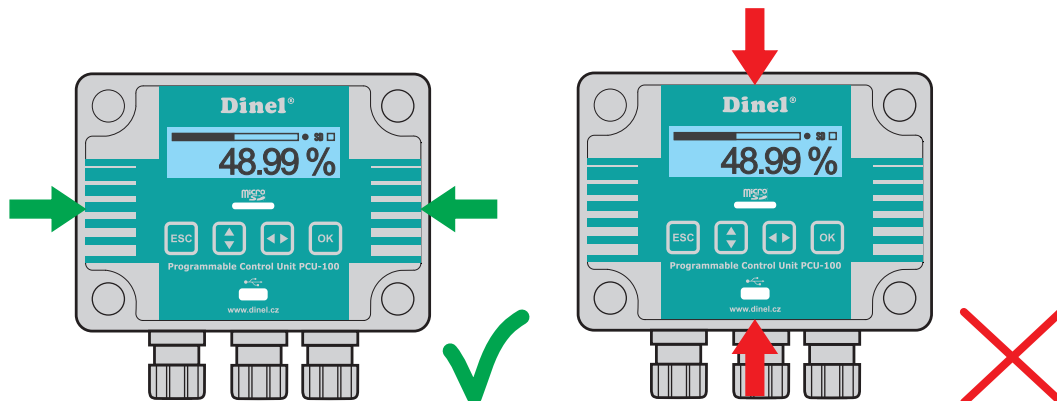

Electrical connection can only be made in a voltage-free state!

The temperature of the internal components of the unit may under specific conditions exceed a temperature of 60°C after a longer period of time in service. Take care when handling.

- The device may only be connected to the power supply via an easy to reach switch with marked turned off/on positions and must be protected by a fuse or circuit breaker with a value of max. 16 A!



The switch or circuit breaker used as the disconnect device must be in accordance with the IEC60947-1 and IEC60947-3, must be marked and must not be in the network inlet.

- The used connecting cables must be of circular cross-section of the prescribed diameter (2.5 - 6.5 mm). The connection cable must be according to the specifications of the manufacturer rated to the operating voltage (85 - 253 VAC) and the current load corresponding to the rated wattage (6 VA) at this voltage. The insulation material must comply with the operating voltage and endure the ambient temperatures of up to 70 °C. In the case, there is no cable in the penetration, the penetration must be fitted with a plug. Cable grommets must be tightened to the specified torque (3 Nm).

WIRING CONNECTIONS

Power supply inlet	power supply AC lead "L" to the terminal No.1 and lead "N" to the terminal No.2.
Connections of input equipment	current loop "+" to terminal No. 4 and "-" to No. 5
Relay output (galvanically separated solid state relay - SSR)	the connection to the terminals No.6 and No.7.



The external power supply is not connected

- Grounding wire connected to the unit serves always as the functional ground to improve the assembly resistance against EM interference and does not fulfil the protective function. Connection of a functional earth to the unit is possible in one of the two ways while we are choosing the way that allows connection the ground wire on a shorter route:
 1. We will connect the grounding wire inside the unit to the terminal number three where it is assumed to bring the earthing wire to the unit within the power cable.
 2. The grounding wire will be connected to the external earth terminal of the device, which is located on the bottom of the box together with outlets.



The grounding wire is always attached only in one place by using the method 1 or 2. It is never attached in both places at the same time.

EXAMPLE CONNECTION

Basic connection:

An example of the PCU-100-X-I unit connection with the level sensor ULM-53-xx-I is shown here.

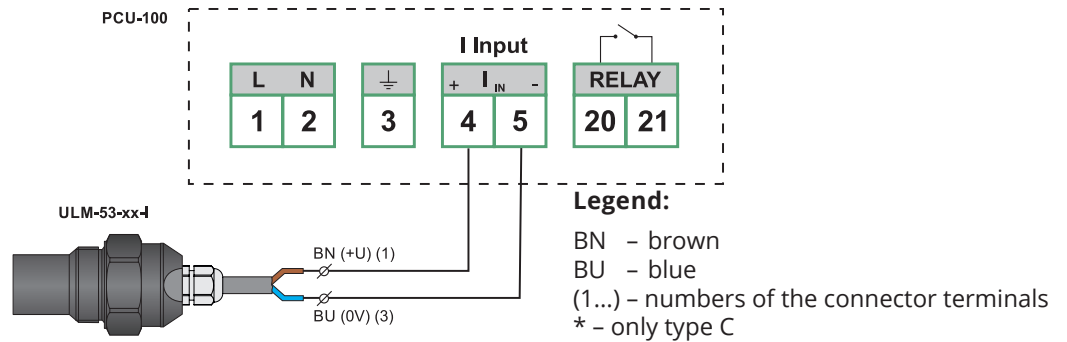

The level transmitter ULM-53-XX-I may be replaced by any other sensor with current output.

Connection with a circuit with shielded cable:

PCU-100-_-I unit with a level meter HLM-35N-_-I.

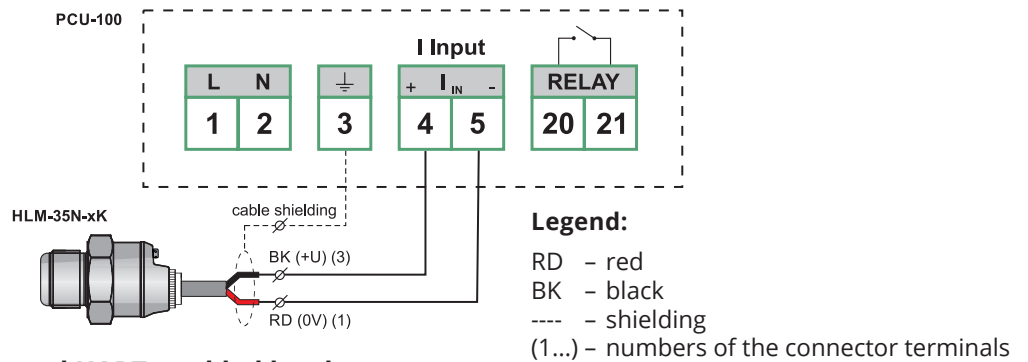

Connection of wiring several HART-enabled level meters:

Here is the wiring of the PCU-100-_-H unit with multiple level meters ULM-70-N-_-_-I.

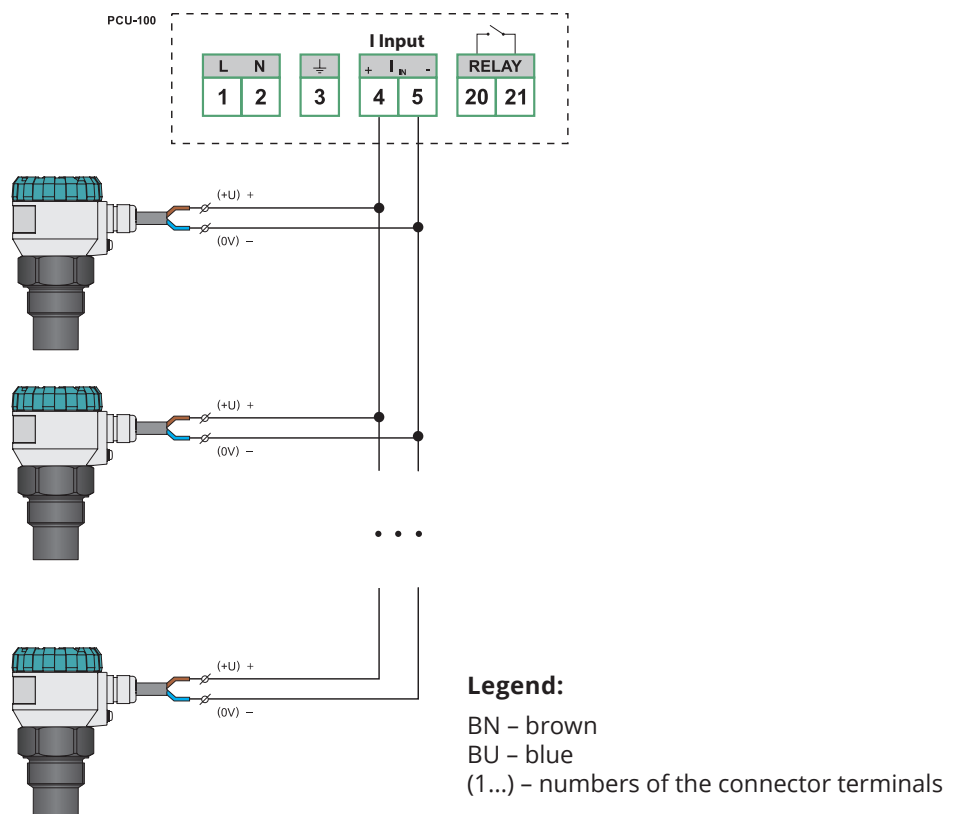

 The ULM-70N-__-__-__-I can be replaced by any other measuring device with current output and HART® protocol support (from Dinel, s.r.o. these are for example GRLM-70 or CLM-70). The devices can also be combined and do not have to be of the same type.

It is important that the measuring devices are in multidrop mode. In the case of level meters from Dinel, s. r. o. this mode is set by changing the polling HART® address to other than 0. A constant current of 4 mA is then flowing through the level meter, independent of the value of the measured quantity, and communication then takes place using the HART® protocol only.

 For proper functionality it is also necessary that all connected devices have a different polling address.

SETTING AND READING OF DATA

- The unit can be set using a configuration application that can be freely downloaded from the Dinel website. For connecting the unit to the computer, there is a microUSB port on the unit's front panel.
- The unit version with an LCD display (PCU-100-D) can also be fully set using a graphic menu controlled by four membrane keys.
- The logged data from the internal memory of the unit can be exported to a micro SD card for additional processing. For access to the slot for memory card insertion, it is necessary to withdraw first the transparent polycarbonate housing of the front panel that is held in place by 4 plastic screws (see manual chapter Mechanical Assembly).
- In the default configuration export of data to the SD card will take place immediately after inserting a memory card into your device. This behaviour is possible to modify in the configuration and run data export manually through the menu (see manual chapter 9.5.2 Automatic export of data on the SD card) or configuration application of the unit.
- The unit can also be configured for automatic export of the data to the SD card, whether periodically or when the internal memory is full (see manual chapter 9.5.3 Configuration of the backup mode). For the functioning of these automatic backups, it is necessary to keep the memory card inserted in the unit. After the completion of the work with the data, it is necessary to return the transparent polycarbonate housing of the front panel back on its place and properly tighten the screws to achieve full coverage.

 Be extremely careful when placing the cover in place. It is not possible to settle the front cover arbitrarily, there are located protrusions on the bottom of the housing and on the body of the boxes. At bad settlement, these protrusions may prevent the full engagement of the seal and the achievement of full coverage.

- The data are stored on a memory card in CSV format. Path to the stored file will be as follows: /PCU-100/SNXXXXXX/DATA_YYY.CSV, where XXXXXX is the serial number of the unit and YYY sequence number of the file. Up to 999 files with exported data can be saved for each unit of the PCU-100 without overwriting the previous file.

 The delimiter in a CSV file is dependent on the selected menu language. EN: “,” CZ: “;”

ORDER CODE

PCU-100

SET-UP ELEMENTS

- D** with LCD display
- L** without LCD display

UNIT INPUT

- I** current input
- H** communication with the sensor using the HART® protocol (also allows the use of a standard current input identical to type I)

OPTIONAL EXPANTION MODULE

- 0** without I/O expansion module
- I** current output module
- G** module GSM

SUPPLY VOLTAGE

- 230 V** AC supply voltage 85 ÷ 253V AC / 50 ÷ 60Hz
- 12 V** 9 ... 26 V DC, 10.4 W

PCU-100 - D - I - 0 - 230 V

EXAMPLE OF CODING

SAFETY, PROTECTION AND COMPATIBILITY

The PCU-100 unit is protected by an internal blow fuse. The current unit input is protected against short circuit.

The electrical equipment of the protection class II. Electrical safety according to EN 61010-1.

The electromagnetic compatibility is ensured by compliance with standards EN 55011, EN 61326-1, EN 61000-3-, EN 61000-3-2, -3-3, -4-2 (4 kV/8 kV), -4-3 (10 V/m), -4-4 (1 kV /2 kV), -4-5 (2 kV), -4-6 (10 V) a -4-11.

PACKIGING, TRANSPORT AND STORAGE

The PCU-100 comes packaged in a cardboard box to protect it from mechanical damage.

Shocks and drops must be avoided during loading and transport.

The PCU-100_ must be stored in dry and covered areas with a humidity of up to 85% without aggressive fumes at temperatures of -10°C to +50°C and protected from the weather.

The manufacturer reserves the right to change the specifications and appearance of the product without prior notice.

Dinel, s. r. o.
U Tescomy 249, 760 01 Zlín
Czech Republic
phone: +420 577 002 000
e-mail: obchod@dinel.cz

www.dinel.cz

version:
11/2023

